

# A3 LITE

## User Manual

Revision 2026-03-28

Thank you for purchasing our products. A3 Lite is a high-performance and functional 3-axis gyro system designed for R/C airplanes. In order for you to make the best use of your gyro and to fly safely, please read this instruction manual carefully and set up the device as described below.



### IMPORTANT NOTES

- Radio controlled (R/C) models are not toys! The propellers rotate at high speed and pose potential risk. They may cause severe injury due to improper usage. It is necessary to observe common safety rules for R/C models and the local law. Read the following instructions thoroughly before the first use of your gyros and setup the gyro carefully according to this manual. We also recommend that you seek the assistance of an experienced pilot before attempting to fly with our gyros for the first time.
- After power on, A3 Lite needs to perform an accurate gyroscope calibration, keep the airplane stationary after power on and wait while the LED flashes blue. The LED will stay solid blue if a slight movement is detected and the calibration will not start until you stop moving the airplane, however, making the airplane level is NOT required during the initialization.
- A stick centering is also required following the gyroscope calibration. Always put all the sticks center (the throttle stick in the lowest position) before power on the airplane, and do not move the sticks until the initialization is done.
- Make sure to check the gyro direction of Aileron, Elevator and Rudder channels after installation and always perform a test of them before each flight. An opposite reaction of the gyro could lead to losing control or even crash!
- It is recommended to use the supplied 3300uF/16V capacitor to get a more stable and secure working voltage for the gyro. The capacitor can be plugged onto any one of the free connectors of the gyro or receiver.

# INSTALLATION

Use one of the supplied double-sided tape to attach the gyro to your airplane firmly. For best performance, the gyro should be mounted as close to the C.G. as possible, and the housing edges must be aligned exactly parallel to all three rotation axes of the plane. The gyro can be attached flat or upright, and even upside down, however, in fact, you only need to ensure that the shorter edge of the gyro always points toward the front (or rear) of the airplane.

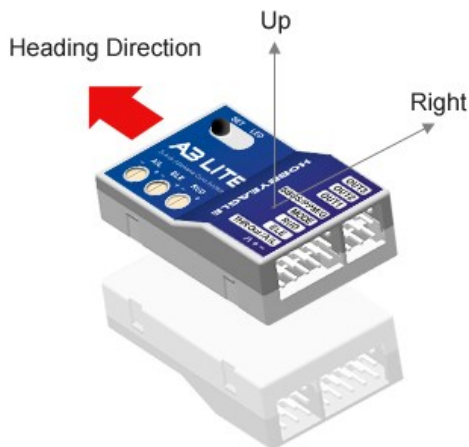

① Flat, face up or down

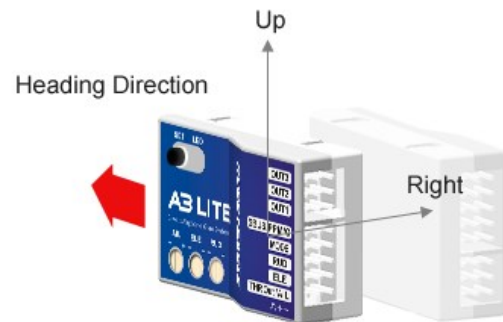

② Upright, or upside down

## NOTES

- Never use the hot-melt glue or nylon ties to fix the gyro onto the airplane!
- You need only one piece of the tapes each time, a soft or thick mounting may probably impact the performance of the gyro.
- The gyro is a sensing device, please make enough space around it and keep as far away from other electronic devices or wires as possible.

# CONNECTION

## NOTES

- [MODE] is used for flight mode switching of the gyro, connect it to a 3-way switch channel of the receiver to switch the flight mode in flight.
- [SBUS/PPM/G] is used for remote master gain adjusting, connect it to a proportional channel of a volume or slide lever of the transmitter to tune the master gain in flight.
- The ESC or throttle servo is connected to the throttle channel of the receiver directly without passing through the gyro.
- Pay attention to the polarity of the plugs. The orange signal line must always be on the top and the brown on the bottom.

# STANDARD PWM RECEIVER CONNECTION

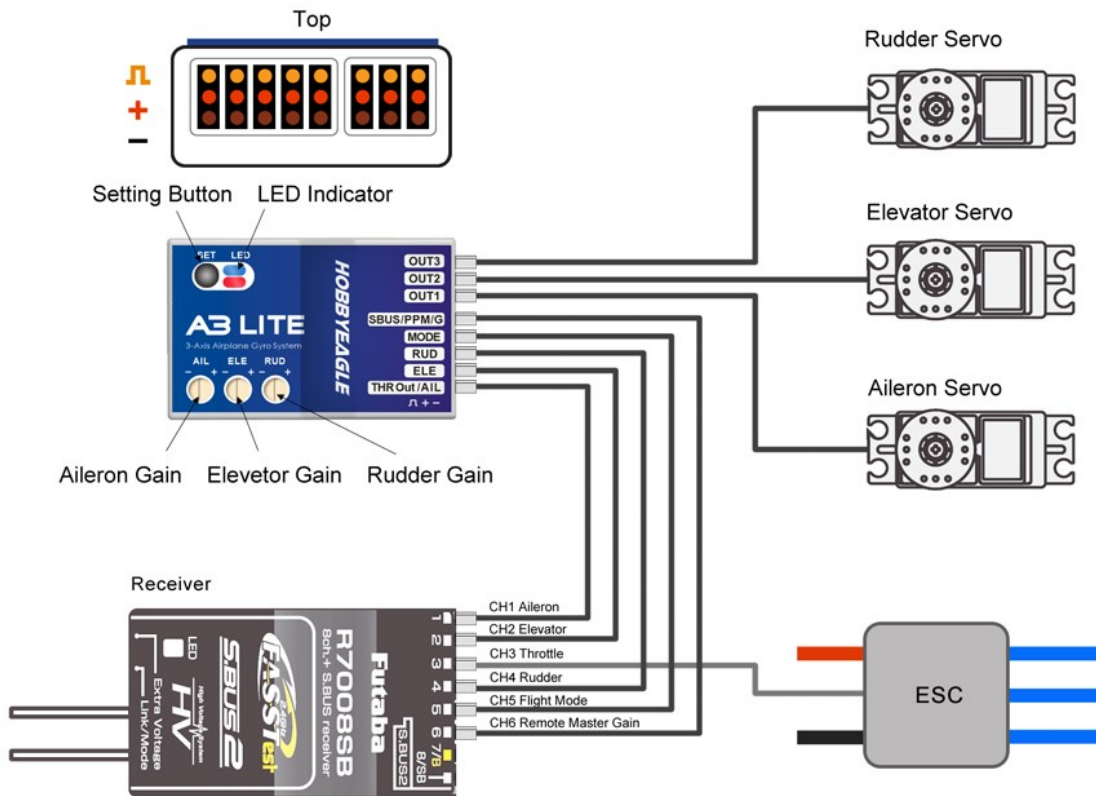

# SINGLE-LINE RECEIVER CONNECTION

A3 Lite supports PPM, SBUS and CRSF (F/W V2.0 or above required) serial receivers which allows you to connect the gyro to the receiver with one single wire. When using a specific type of these receivers the appropriate type of receiver channel allocation will be preset in the A3 Lite. Please refer to the table below and check if your radio transmits the channels in the correct order. If you use a standard PWM receiver with standard wiring layout the channel mapping does not apply. When A3 Lite is operating in single line receiver mode, the [THR Out/AIL] can be used as the throttle output channel for the ESC or the throttle servo if a mini receiver is being used which has no additional output connectors.

 Please note that the Remote Master Gain is disabled in single line mode as default. Choose a channel number for gain channel in item 8 of the *Setup Menu* to activate this feature if needed.

**Table 1: Default Channel Mapping for Single Line Receivers**

Serial Receiver Protocol	AIL	ELE	THR	RUD	MODE	GAIN
PPM Receiver	CH1	CH2	CH3	CH4	CH5	-
SBUS – Futaba/Generic	CH1	CH2	CH3	CH4	CH5	-
CRSF – TBS/ELRS ①	CH1	CH2	CH3	CH4	CH5	-

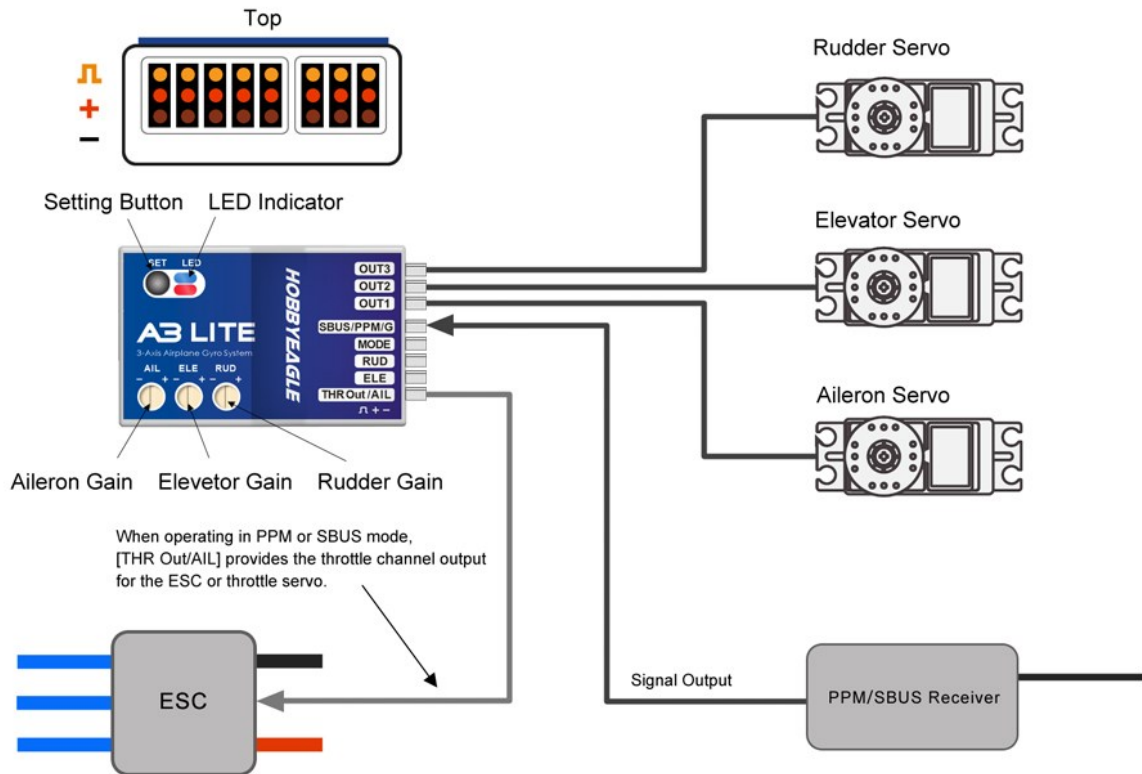

① Newly added in F/W V2.0.



## FLIGHT MODES

A3 Lite provides 3 flight modes which can be switched by a 3-position switch of the transmitter during flight. The factory default mode allocation of the switch is **NORMAL – GYRO OFF - LOCK**. The color of the LED shows the current flight mode of the gyro while in use.

**Table 2: Colors of the LED for Flight Modes**

Position-1		Solid Blue	NORMAL Mode
Position-2		LED Off	GYRO OFF Mode
Position-3		Solid Red	LOCK Mode

### 1. GYRO OFF MODE

When operating in *GYRO OFF* mode the gyro will be deactivated completely, and the airplane will be completely under the control of your transmitter as it was before installing the gyro. This mode is usually used for testing purpose only.

## 2. NORMAL MODE

The *NORMAL* mode, also known as the '*Rate mode*', is the most basic function of the gyro. It works based on the rotation rate control of each axis of the airplane. When operating in this mode, the gyro will only correct currently occurring rotational movements, a momentary reaction will be applied to the servos when the airplane rotating on corresponding axis, after rotation the servos will move back to their neutral position as soon as the airplane standing still immediately. The *NORMAL* mode can effectively improve the stability and precision of the airplane and reduce the stall point.

## 3. LOCK MODE

The *LOCK* mode is also known as the '*Attitude Lock mode*', '*3D mode*' or '*AVCS mode*'. Different from *NORMAL* mode, the gyro will perform a permanent correction for rotational movements on each axis constantly. That is when you release the sticks the airplane will stop and lock its current position immediately. This mode is well suited for practicing basic 3D maneuvers such as hovering or knife edge. Since it can help you to lock the attitude of the airplane, it is also helpful for landing.

# GAIN ADJUSTMENT

## BASIC GAIN

There are 3 trimming potentiometers on the front of the A3 Lite. They are used to adjust the basic gain of the gyro for Aileron, Elevator and Rudder separately. Clockwise for increase, anticlockwise for decrease. Basic gain determines the momentary reaction strength of the gyro. In general, the higher the gain the harder the airplane will stop after rotation and the more stable and precise the airplane will fly. But if the gain is too high the airplane will tend to oscillate at high frequency on the corresponding axis. If too small, the operation and stability will not be so good and the airplane does not stop precisely and overshoots. The gyro will be deactivated completely if you turn the basic gain to 0%.

For the first flight test it is recommended to start with a lower basic gain setting (e.g. 30%) and switch the gyro to *NORMAL* mode. In case the airplane starts to oscillate in flight then reduce the gain of the corresponding axis. If the control feels weak and imprecise and does not hold position when stopping then increase the gain, according to this approach, fine tune the basic gain until you get the best performance.

## REMOTE MASTER GAIN

The [SBUS/PPM/G] is used to control the remote master gain for parallel PWM receiver. You can make a linear adjustment by using a volume or slide lever on your transmitter or make a 3-level gain selection using a 3-position switch. This function is optional, the master gain will always default to 100% if you do not connect it. Master gain will not affect the basic gain setting on the gyro.

# SETTING METHOD

## Setup Menu

To get into the *Setup Menu*, press and hold the button for about 2 seconds until the LED starts flashing Blue and Red quickly. The *Setup Menu* contains 8 setting functions which normally only need to be setup once after installation.

## Function Selection

In the *Setup Menu*, the LED will flash Blue and Red several times every 3 seconds in a loop and the number of LED flashes shows which function item you are currently in. For example, one Blue and Red flash means the first setting “*Aileron Gyro Direction*”, after waiting about 3 seconds, a twice Blue and Red flash means the second setting “*Elevator Gyro Direction*”, and so on.

## Option Switching

When you reach the function that you wish to operate in, short press the button to get into it. After entering in, the current selected option is indicated by the color of the LED. Each short press of the button advances the option to the next value. After you finish making your selection, just wait for 5 seconds until the LED starts blink quickly which indicates that the modified is saved and then you will be brought back to the *Setup Menu* level automatically. If you do not want to change anything, just wait for timeout without any operation.

## Exit of Menu

To exit the menu just keep the button pressed for 2 seconds again until the LED starts flashing Blue and Red quickly.

**SETUP MENU TABLE** (\* are the default settings)

	Functions	LED Status	Solid Blue	Solid Red	Solid Blue&Red	Blue Flashing	Red Flashing	Blue&Red Flashing
1	Aileron Gyro Direction	1 flash	Normal *	Reversed				
2	Elevator Gyro Direction	2 flashes	Normal *	Reversed				
3	Rudder Gyro Direction	3 flashes	Normal *	Reversed				
4	Wing Type	4 flashes	Standard *	Delta-wing	V-Tail			
5	Receiver Type	5 flashes	PWM *	PPM	SBUS	CRSF		
6	Mount Orientation	6 flashes	Flat *	Upright				
7	Servo Frequency	7 flashes	50Hz *	125Hz	250Hz			
8	Remote Master Gain	8 flashes	Disabled *	CH6	CH7	CH8	CH9	CH10

\* The options in red font are newly added in F/W V2.0.

## 1-3. GYRO DIRECTION

The top 3 items of the *Setting Menu* is used to reverse the gyro direction for *Aileron*, *Elevator* and *Rudder*. The color of LED shows you the gyro direction currently selected, the default setting is *Normal (Solid Blue)*. Each short press of the button will switch between *Normal* and *Reversed*. After you finish making your selection, just wait for 5 seconds until LED starts blink quickly which indicates that the modified is saved and then you will be brought back to the *Setup Menu* level automatically.

LED Color	Description
Solid Blue	Normal (default)
Solid Red	Reversed



### VERY IMPORTANT!

It is extremely important to make sure that the gyro reacts in the correct direction for each channel before flight. An opposite reaction of the gyro could lead to losing control or even crash!

**Check the gyro direction for Aileron** Quickly move the right wing downward around the roll axis, the right aileron surface should flap down and the left flap up as shown below.

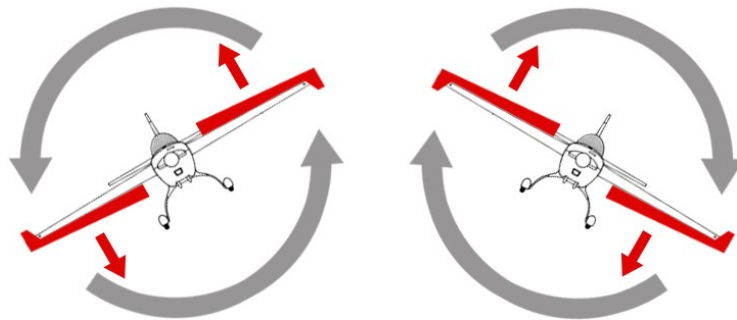

**Check the gyro direction for Elevator** Quickly move the nose of the airplane downward around the pitch axis, the elevator surface should flap up as shown below.

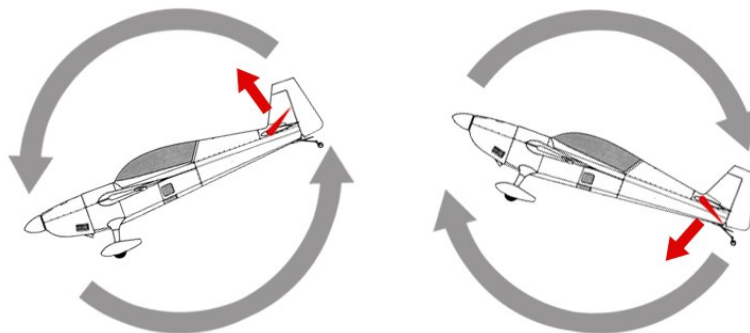

**Check the gyro direction for Rudder** Quickly move the nose of the airplane to the left around the yaw axis, the rudder surface should flap right as shown below.

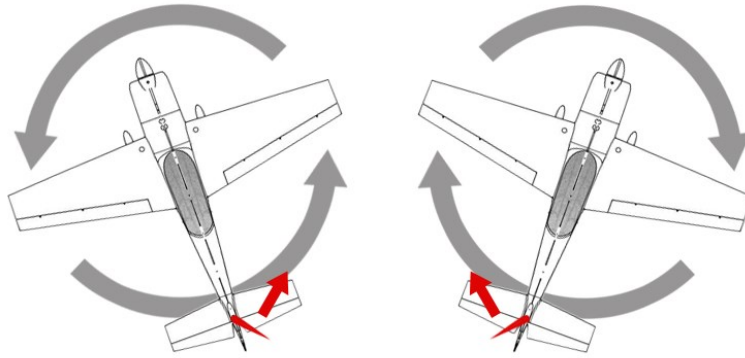

## 4. WING TYPE

The 4<sup>th</sup> item of the *Setup Menu* is used to setup the wing type. A3 Lite supports standard fixed-wing, flying-wing (delta-wing) and V-tail. The color of LED shows you the wing type currently selected. The default setting is *Standard (Solid Blue)*, each short press of the button will switch to the next type. After you finish making your selection, just wait for 5 seconds until LED starts blink quickly which indicates that the modified is saved and then you will be brought back to the *Setup Menu* level automatically.

LED Color	Description
Solid Blue	Standard (default)
Solid Red	Flying-wing (Delta-wing)
Solid B&R	V-Tail

### ! NOTES

- Make sure that there are no mixing functions active on your transmitter. Have a look at the radio's servo monitor and verify that each stick controls only one output channel.
- If two aileron servos are being used, please connect a Y-extended lead to [OUT1].
- Most flying-wings have no rudder, in this case, [RUD] is unnecessary to connect.

## Servo Connection Illustration

Standard Wing Type

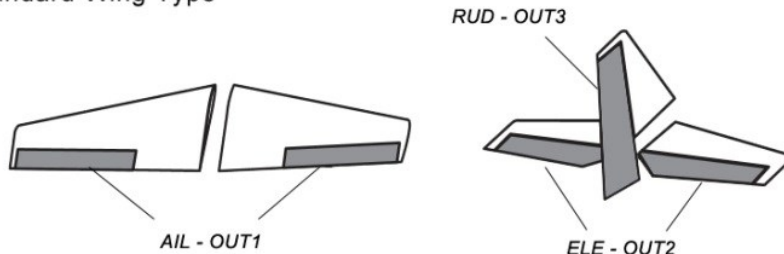

Flying Wing (Delta)

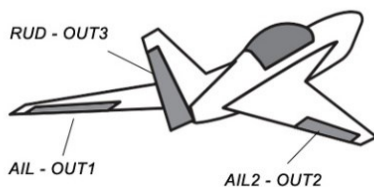

V-TAIL

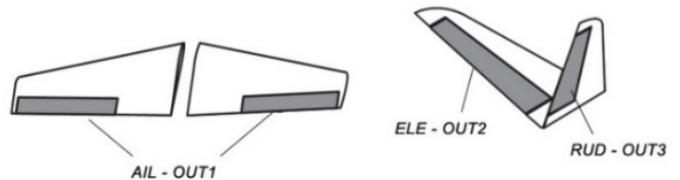

## 5. RECEIVER TYPE

The 5<sup>th</sup> item of the *Setup Menu* is used to choose the receiver type. The color of LED shows you the receiver type currently selected. The default setting is *PWM Receiver (Solid Blue)*, each short press of the button will switch to the next value. After you finish making your selection, just wait for 5 seconds until LED starts blink quickly which indicates that the modified is saved and then you will be brought back to the *Setup Menu* level automatically. Restart the gyro to make the new receiver type setting take effect!

(CRSF is the new option newly added in F/W V2.0)

LED Color	Description
Solid Blue	PWM Receiver (default)
Solid Red	PPM Receiver
Solid B&R	SBUS Receiver
Blue Flash	CRSF Receiver

## 6. MOUNT ORIENTATION

The 6<sup>th</sup> item of the *Setup Menu* is used to setup the mounting orientation of the gyro. The color of LED shows you the orientation currently selected. The default setting is *Flat (Solid Blue)*, each short press of the button will switch between *Flat* and *Upright*. After you finish making your selection, just wait for 5 seconds until LED starts blink quickly which indicates that the modified is saved and then you will be brought back to the *Setup Menu* level automatically.

LED Color	Description
Solid Blue	Flat (default)
Solid Red	Upright

The setting here should be the same as the mounting orientation of your unit installed in the airplane, otherwise the gyro will not work normally.

## 7. SERVO FREQUENCY

The 7<sup>th</sup> Item of the *Setup Menu* is used to select the working frequency of the servos. The color of LED shows you the frequency currently selected. The default setting is *50Hz (Solid Blue)*, each short press of the button will switch to the next value. After you finish making your selection, just wait for 5 seconds until LED starts blink quickly which indicates that the modified is saved and then you will be brought back to the *Setup Menu* level automatically.

LED Color	Description
Solid Blue	50Hz (default)
Solid Red	125Hz
Solid B&R	250Hz

Please note that the analog servos can only work with 50Hz. If you do not know what the maximum update rate that is tolerated by your servos never use more that 50Hz. The higher the frequency the better it is for the flight performance of the gyro but you must check the servo specifications before increasing the setting. Otherwise, the servos may get damaged!

## 8. REMOTE MASTER GAIN

The 8<sup>th</sup> item of the *Setup Menu* is used to enable or disable the remote master gain function for PPM, SBUS or CRSF receiver mode. The master gain is disabled as default when leaving the factory, you need to choose either channel 6 or channel 7 as the gain channel to activate this feature if needed.

(Channel 8, 9, 10 are the new options newly added in F/W V2.0)

LED Color	Description
Solid Blue	Disable (default)
Solid Red	Channel 6
Solid B&R	Channel 7
Blue Flash	Channel 8
Red Flash	Channel 9
B&R Flash	Channel 10







### ★ FACTORY RESET

To restore the gyro to factory default settings, press and hold the button while turning on the power of the gyro, release it when LED starts flash Blue and Red. (FYA: the button needs to be hold for more than 4 seconds), after successfully entering the program the LED will remain flashing Blue, press and hold the button again for about 2 seconds until the LED starts flash Blue quickly, release the button to confirm the reset. After a successful reset the gyro will start the initialization automatically.

### ★ FIRMWARE VERSION DISPLAY

To check the current firmware version number, press and hold the button while turning on the power of the gyro, keep holding the button for more than 10 seconds, release it when LED starts flash Blue and Red quickly. Then the number of LED flashes Blue shows the major version number, and the number of LED flashes Red shows the minor version number. For example, one Blue flash followed by nine Red flashes represents V1.9, and so on. The gyro will start initialization after displaying the version number. Please note that some early versions of the gyro may not be able to display the version information.

## LED DESCRIPTIONS

	Blue, Flashing	Power-on initialization and self-test
	Solid Blue	NORMAL Mode
	Solid Red	LOCK Mode
	LED Off	GYRO OFF Mode
	Red, Slow Flashing	No signal reception
	Blue, Fast Flashing	Calibrating or testing
	Red, Fast Flashing	Gyroscope sensor error

## SPECIFICATIONS

<b>Main Controller:</b>	32-bit MCU	<b>Sensor:</b>	MEMS 3-axis sensor
<b>Gyro Scale Range:</b>	± 2000dps	<b>Size:</b>	43 × 27 × 14mm
<b>PWM:</b>	800 ~ 2220uS, Neutral 1500/1520uS, 50Hz ~ 250Hz		
<b>Input Voltage:</b>	4.8V ~ 8.4V (H.V. 2S Lithium Battery Supported)		
<b>Operating Temperature:</b>	-10℃ ~ 50℃	<b>Weight:</b>	10g (excluding wires)